

Project: _____
 Customer: _____
 Tru-Brix Order Number: _____
 Plant: CUSHWA Color: _____ Size: Oversize
 Date: 11/2/09 By: D. ARTZ II Page: _____
 Drawing Name: RIGHT OX-90* Reference: _____

Tru-Brix®
 Real Brick Siding

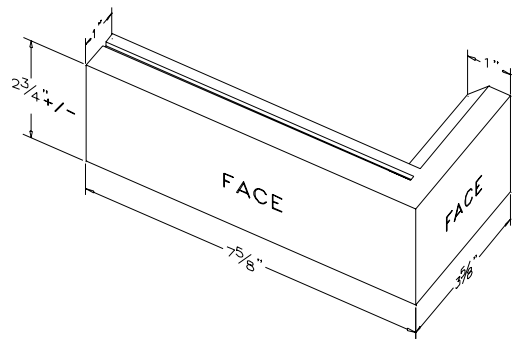
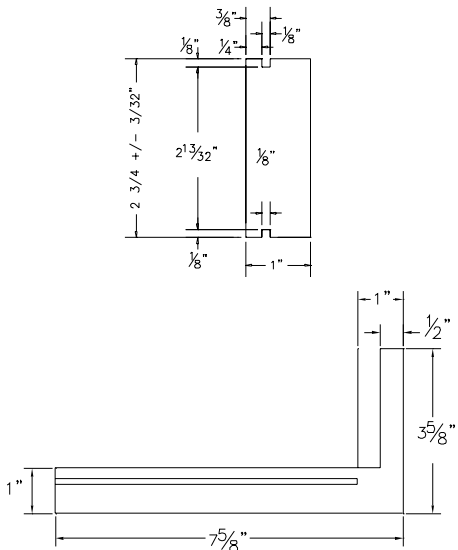

H:\ARTZ II\Tru-Brix\Standard Shapes\Right OX-90.dwg

BELOW LINE FOR REDLAND'S USE ONLY:

AUTHORIZED FOR PRODUCTION BY:

DATE: